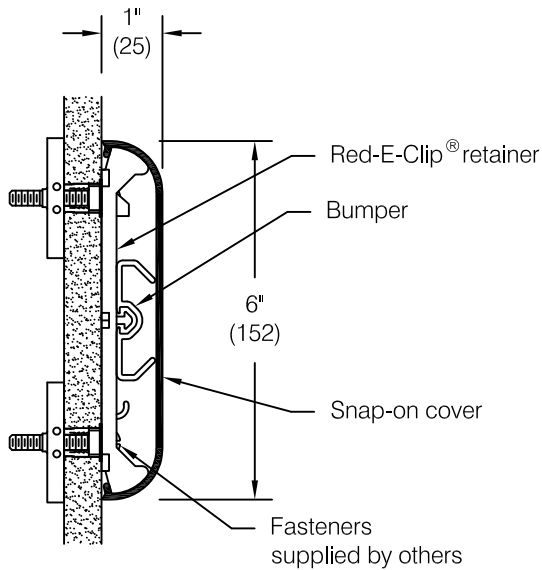
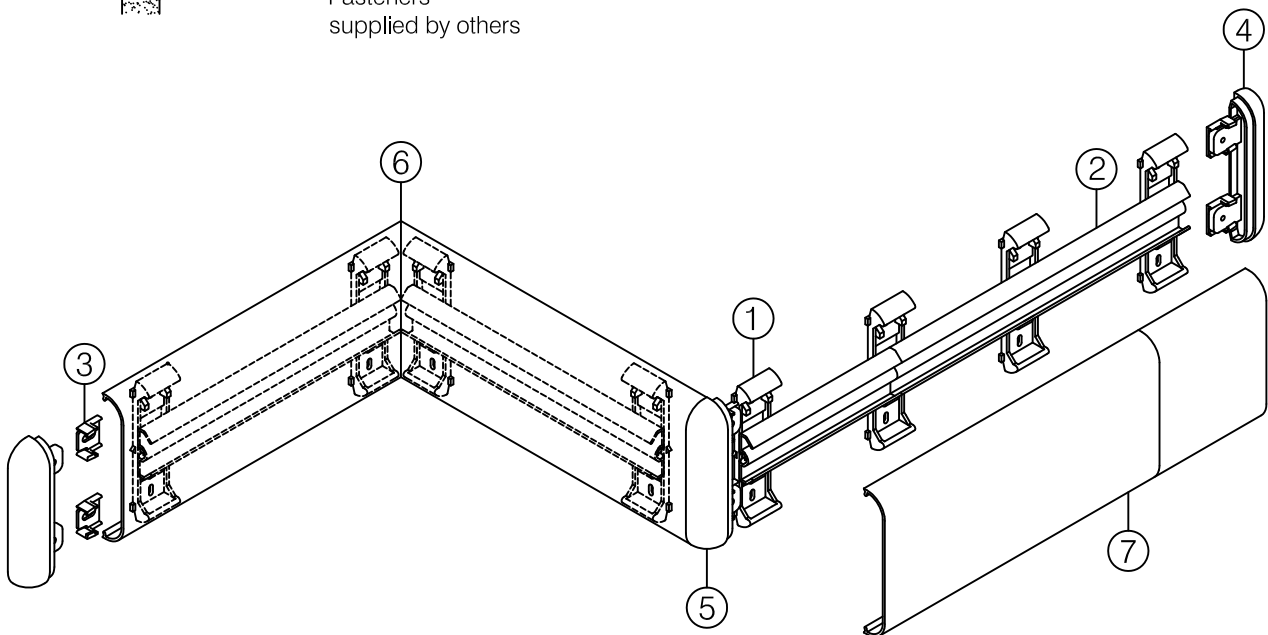


## ***WG-6CL Series Wall Guards***



This installation instruction is applicable to:

WG-6CL  
 WGG-6CL  
 WGX-6CL



### Component Part Numbers:

- 1) WG-6C-CLIP-1 Red-E-Clip® retainer
- 2) WGV-8CL-12-1 Rigid bumper
- 3) WG-8C-SPACER-1 Accessory spacer
- 4) ETC-6C-0-XXX End cap with spacers
- 5) OTC-6C-0-XXX Outside corner with spacers
- 6) Field mitered corner
- 7) Snap-on cover
  - WGV-6-12-XXX standard textured
  - WGVG-6-12-XXX grooved and textured
  - WGVX-6-12-XXX accent strips (5) and textured

**Step 1:** Determine top of wall guard height and snap a chalk line 3" below to locate centerline of wall guard and to provide a reference line for locating Red-E-Clip® retainers, see **fig 1**.

**Important:** Store material in a clean dry place where the temperature is maintained between 50°F (10°C) and 100°F (38°C). Walls and rooms should be maintained at a minimum of 65°F (18°C) for at least 48 hours prior to installation. Acclimate materials to normal building conditions for at least 24 hours before cutting and installing.

**Step 2:** The retainer system consists of a Red-E-Clip® retainer base, or "Clip", and an extruded bumper cushion shipped separately, see **fig 2**. Secure clips to wall by aligning the molded location pointers in the clip with the chalk line, see **fig 3**. The clip may be installed with either end up.

*Note:* A continuous metal backer plate should be used in all drywall installations to allow freedom in the left-to-right placement of the Red-E-Clip®. In the absence of a backer plate align each clip with a metal stud. When necessary a clip may be installed away from a stud or backer plate using the appropriate hardware, see **step 4** below.

**Red-E-Clip® must be:**

- Spaced not to exceed 16" on center
- Located adjacent to end cap and corner accessories, see **step 3**
- At each snap-on cover butt-joint, see **fig 8**

**Step 3:** A Red-E-Clip® must be installed adjacent to each molded accessory. Begin by installing a spacer on each of the accessory mounting tabs, see **fig 4**. The Red-E-Clip® has four accessory alignment tabs used to facilitate positioning of the molded components with respect to the clip, see **fig 5**. Temporarily locate the accessory and Red-E-Clip® combination by holding them temporarily in their desired position. Remove the accessory and fasten the Red-E-Clip® in place. It is also possible to locate the clip by measuring 3 13/16" to 3 7/8" from the outer edge of the desired accessory location or 1" to 1 1/16" from the inner edge, see **fig 6**.

*Note:* It is critical to install the clip and the accessory perpendicular to the chalk line to ensure a proper fit with 6" snap-on cover.

**Step 4:** Secure Red-E-Clip® assemblies to wall with the appropriate hardware according to wall condition.

**Suggested hardware :**

- Drywall with metal backing : #8 Drill point drywall screw or #8 pan head or hex washer head sheet metal screw.
- Drywall without stud or backing : Plastic Alligator® insert with #8 pan head or hex washer head sheet metal screw or 3/16" Toggler® brand toggle bolts with pan head machine screw.
- Masonry : Plastic Alligator® insert with #8 pan head or hex washer head sheet metal screw or 3/16" hex washer head Tapcon® (or similar fastener).

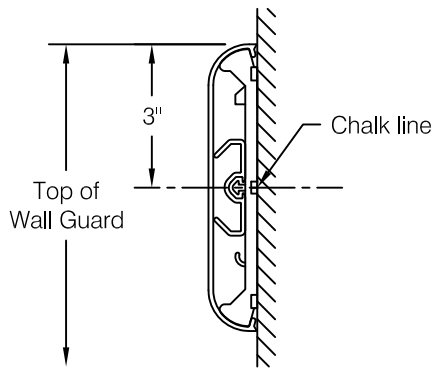
**Step 5:** Secure accessory components in place using the Red-E-Clip® alignment tabs as a guide. Be certain to adjust the accessory as required to ensure it is square with the chalk line. Install with hardware described in **step 4**.

**Step 6:** Cut and install the extruded bumper so that butt joints are centered over a clip. Install the bumper by hooking it over the "arrowhead" retainer in the clip and then tapping into place so that bumper is fully engaged on the retainer, see **fig 7**.

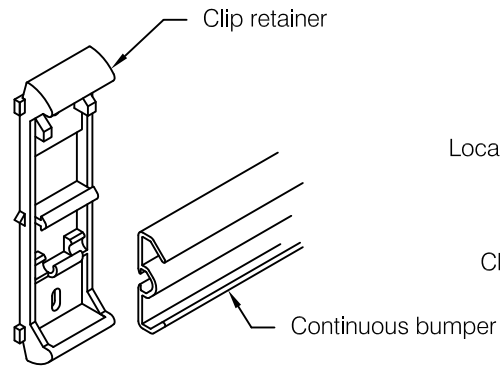
**Step 7:** Measure between accessories and cut the snap-on cover. Miter cut the cover for all inside corners and special angles not accommodated by the molded accessories. Cut and install cover so that butt joints are centered over a retainer clip, see **fig 8**. Do not align butt joints in cover with butt joints in bumper.

**Important:** All cuts must be square and deburred.

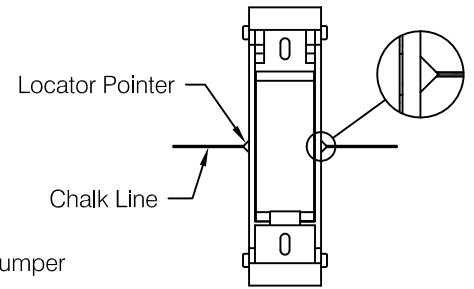
**Step 8:** Snap cover in place over retainer clips.



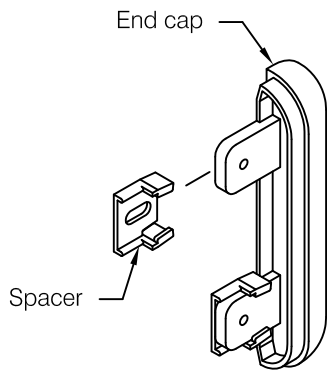
**fig 1**



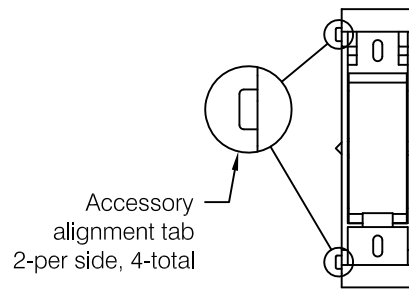
**fig 2**



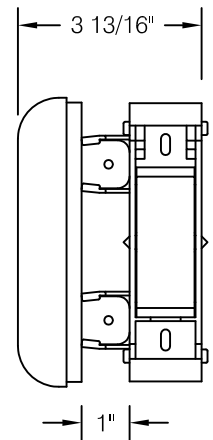
**fig 3**



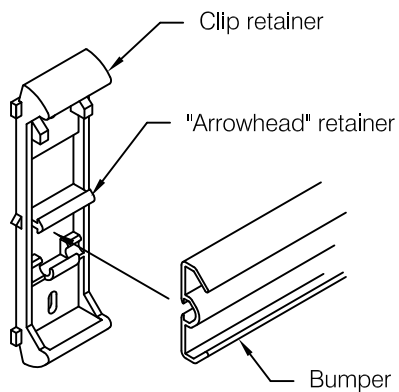
**fig 4**



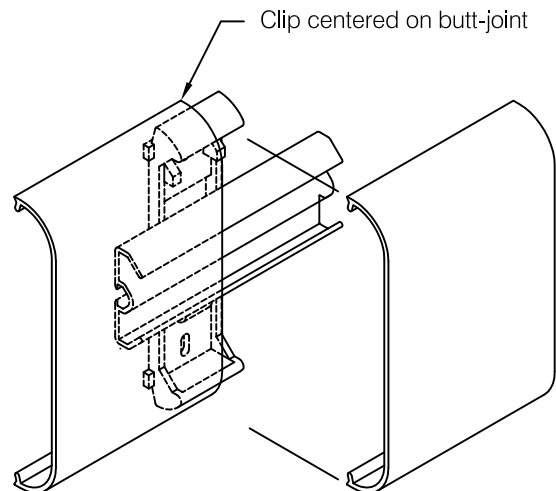
**fig 5**



**fig 6**

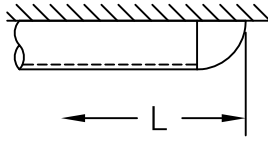


**fig 7**

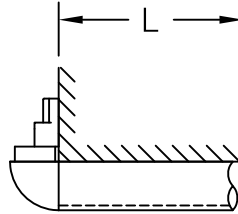


**fig 8**

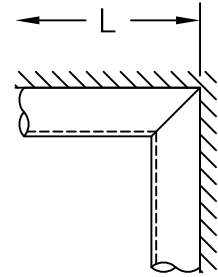
## Cutting Adjustment Diagrams and Schedule



End Cap



Outside Corner



Inside Corner

### Vinyl Cover

End Cap	L - 1"
Outside Corner	L - 0"
Inside Corner	L - 0" (Field Miter)

Important: Install Red-E-Clip<sup>®</sup> retainers and molded accessories before cutting the snap-on cover.

## Minimum Layout Configurations

