

WG-3 Series Wall Guards

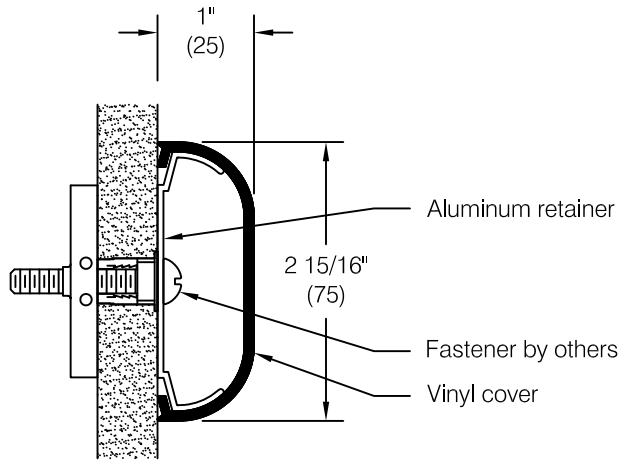

This installation instruction is applicable to:

WG-3
 WGG-3

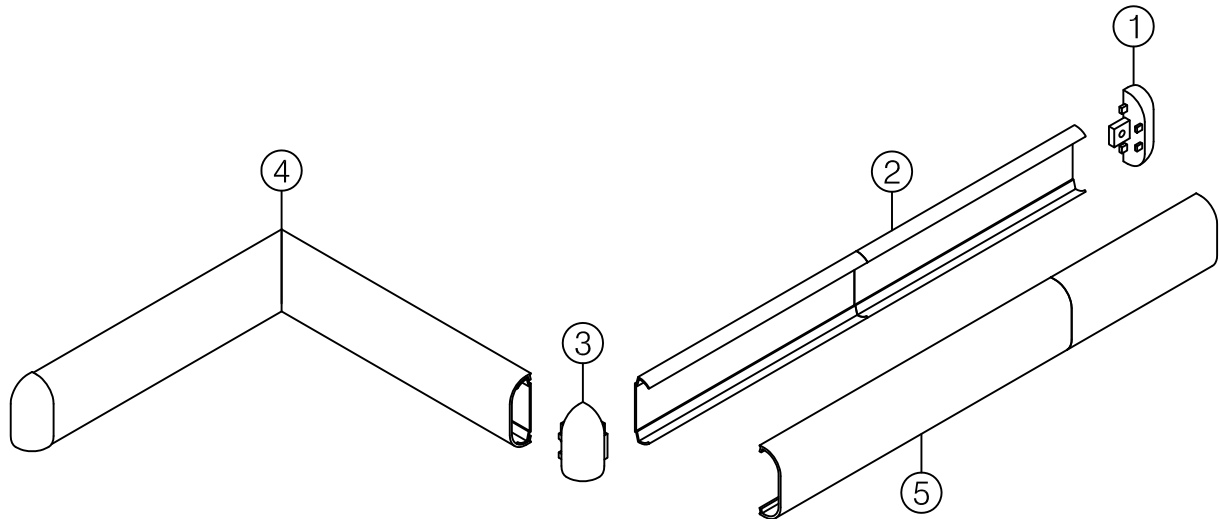

Component Part Numbers:

- 1.) ETC-3 left/right end cap
- 2.) WGAR-3 aluminum retainer
- 3.) OTC-3 outside corner
- 4.) Mitered corner
- 5.) Snap-on cover
 WGV-3-12-XXX standard textured
 WGVG-3-12-XXX grooved and textured

WG-3 Wall Guard Installation Instructions

- Step 1:** Determine top of wall guard and snap a chalk line 1/8" below to locate top of aluminum retainer, see **fig 1**.
- Important:** Store material in a clean dry place where the temperature is maintained above 50°F (10°C). Walls and rooms should be maintained at a minimum of 65°F (18°C) for at least 48 hours prior to installation. Acclimate materials to normal building conditions for at least 24 hours before cutting and installing.
- Step 2:** Cut aluminum retainer. See **Cutting Adjustment Diagrams and Schedule** for adjustments to aluminum retainer length at end caps, inside corners, and outside corners. Refer to **Minimum Layout Configurations** for additional information. Aluminum should be mitered to accommodate outside corners that are not 90° and all inside corners.
- Important:** All cuts must be square and deburred.
- Step 3:** Pre-drill clearance holes in aluminum retainer along the centerline of the retainer using a #15 (.180") bit for #8 fastener or a #7 (.201") bit for #10 and 3/16" fasteners, see **fig 2**. Space holes at 32" on center. Adjust spacing to accommodate studs as necessary. Do not pre-drill at locations that will interfere with installation of molded accessories.
- Note:* Drill point fasteners may be used without pre-drilling aluminum on drywall installations having continuous metal backer or studs. Continue to pre-drill at locations where no backing or stud is available.
- Step 4:** Pre-drill for attachment of molded accessories by inserting accessory in end of retainer. Press firmly to ensure molded part is seated squarely against the aluminum.
- Drywall Installation:* Using the accessory as a template pre-drill clearance holes for mounting through to metal backer or stud or pre-drill pilot holes using #29 (.136") bit for #8 fastener or a #21 bit (.159") for #10 fastener for attaching accessories directly to aluminum, see **fig 3**.
- Masonry Installation:* Using the accessory as a template pre-drill clearance holes at mounting locations, see **fig 3**.
- Step 5:** Fasten aluminum retainer to wall using hardware listed below. Align top edge of retainer with chalk line.
- Important:** Begin installation of aluminum at corners allowing for molded accessories. Use the appropriate accessory as a spacing template. See **Cutting Adjustment Diagrams and Schedule** for additional information. Do not fasten through holes pre-drilled for installation of molded accessories until accessories are installed in **step 6**.
- Drywall Installation:* Fasten aluminum retainer to wall using hardware listed below. If it is necessary to install fasteners in locations where there is no metal backing or stud use pre-drilled aluminum as a template to mark and drill wall for Toggler® brand toggle bolts or plastic Alligator® insert in accordance with instructions provided with hardware.
- Masonry Installation:* Using the pre-drilled aluminum as a template, mark and drill the wall at all pre-drilled holes to accept plastic Alligator® insert or 3/16" Tapcon® or similar fastener. Drill in accordance with instructions provided with hardware.
- Suggested hardware :**
- Drywall with metal backing : #8 or #10 Drill point drywall screw or #8 or #10 drill point pan head or hex washer head sheet metal screw.
 - Drywall without stud or backing : Plastic Alligator® insert with #8 or #10 pan head or hex washer head sheet metal screw or 3/16" Toggler® brand toggle bolts with pan head machine screw.
 - Masonry : Plastic Alligator® insert with #8 or #10 pan head or hex washer head sheet metal screw or 3/16" hex washer head Tapcon®.
- Step 6:** Secure accessory components in place using hardware selected in **step 5**.
- Caution:* Use of a flat washer at accessory mounting tabs is recommended to prevent damage to molded part caused by excessive tightening of the fastener.
- Step 7:** Measure between accessories and cut the WGV-3 vinyl cover accordingly. Miter cut the WGV-3 for all angles not accommodated by the molded accessories.
- Important:** All WGV-3 cuts must be square and deburred.
- Step 8:** Snap the WGV-3 cover in place.

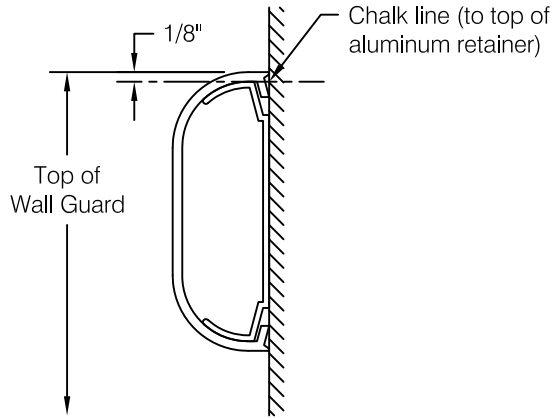

fig 1

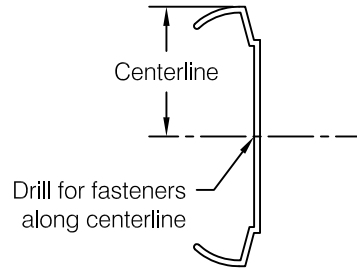

fig 2

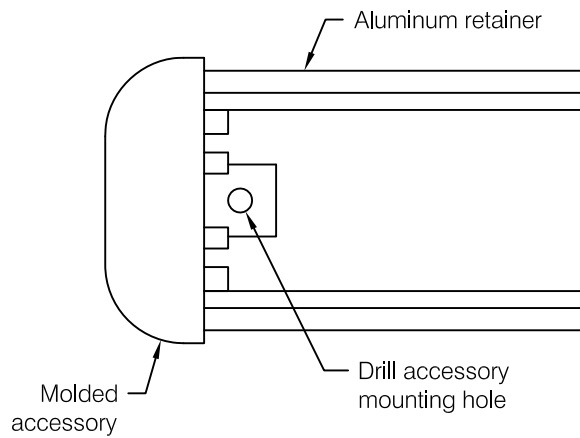
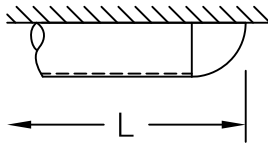
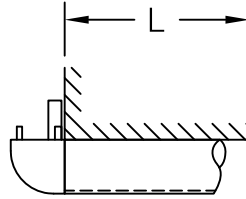

fig 3

Cutting Adjustment Diagrams and Schedule



End Cap



Outside Corner

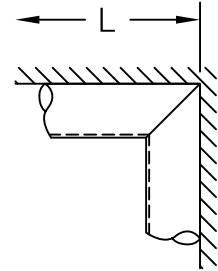

Inside Corner

| | Aluminum Retainer | Vinyl Cover |
|----------------|----------------------|----------------------|
| End Cap | L - 1" | L - 1" |
| Outside Corner | L - 0" | L - 0" |
| Inside Corner | L - 0" (field miter) | L - 0" (field miter) |

Important: install aluminum retainer and molded accessories before cutting the snap-on cover.

Minimum Layout Configurations

